

Electrical Specifications

Frequency Range: 0.25-0.50 MHz
Insertion Loss: 0.2 dB Max.
Isolation: 22 dB Min.
Amplitude Balance: 0.2 dB Max.
Phase Balance: 2° Max.
VSWR: 1.20:1 Max.
Power Rating: 30 Watts Max.

Mechanical

Mounting Method: Threaded Mounting Holes
Connector Type: SMA
Dimensions: 2.10 x 2.10 x 0.50 in.

Environmental

Operating Temperature: -40 to +85°C
Storage Temperature: -55 to +125°C
Shock: 20 G. 11 ms.
Vibration: 20 G. 5 to 200 Hz.

Outline Drawing:

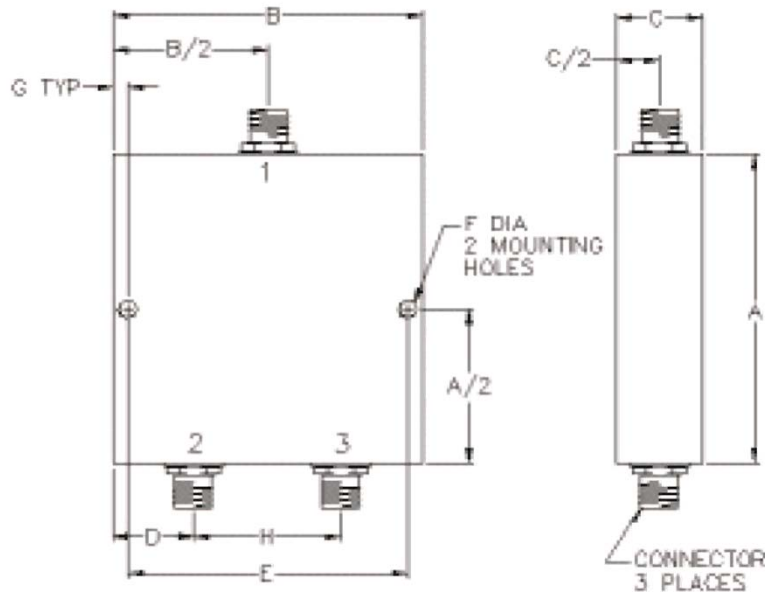

A: 2.10	B: 2.10
C: 0.50	D: 0.55
E: 1.90	F: .125
G: 0.10	H: 1.00